

HYUNDAI

AIR COMPRESSOR

ELECTRIC (3 Phase)

Models HY55200-3 & HY75270-3



User Manual

Licensed by Hyundai Corporation, Korea

CONTENTS

1.	PARTS	3.
2.	INTRODUCTION	4.
3.	ELECTRICAL NOTES	5.
4.	INSTALLATION	5/6.
5.	START UP	6/7.
6.	MAINTENANCE	7/8/9.
7.	PRESSURE SWITCH ADJUSTMENTS	9/10.
8.	ELECTRICAL CONNECTIONS	10/11.
9.	SPECIFICATIONS	12.
10.	DECLARATIONS of CONFORMITY	12.
11.	RECYCLING	13.

1. PARTS.

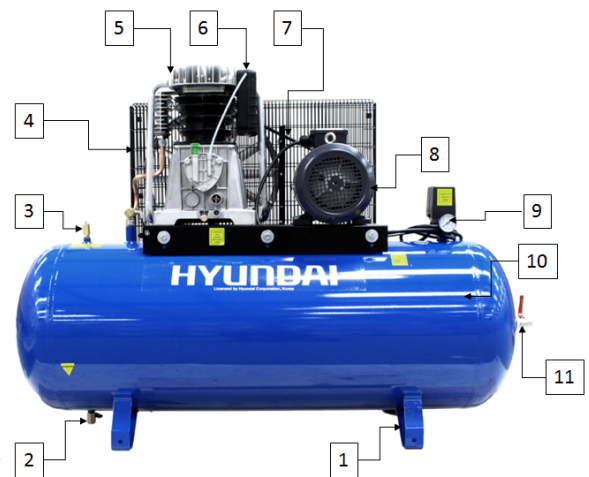
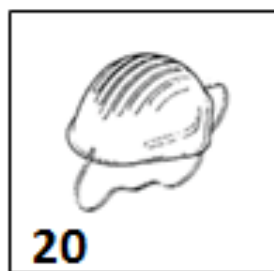
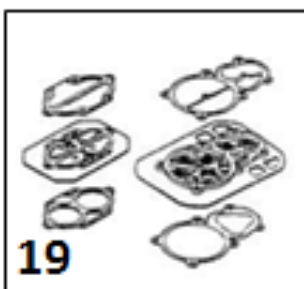
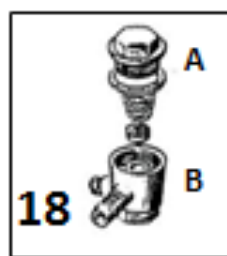
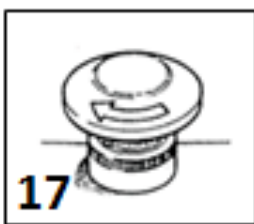
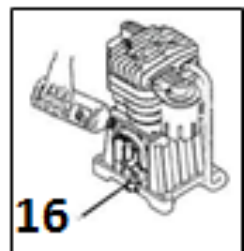
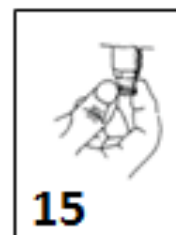
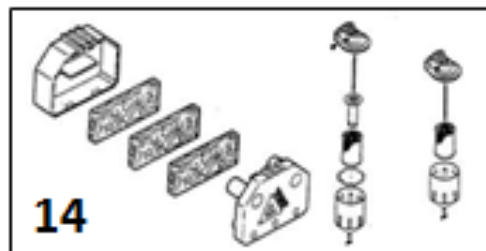
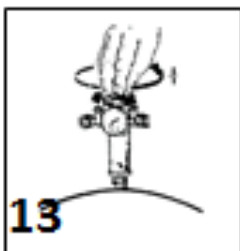
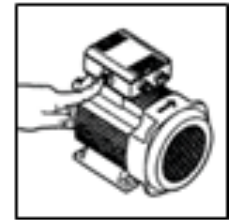
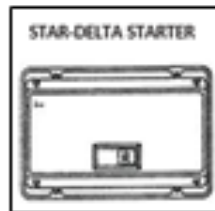
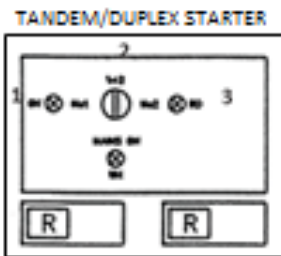
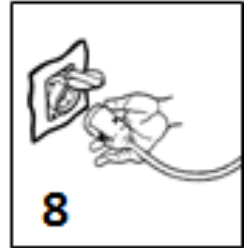
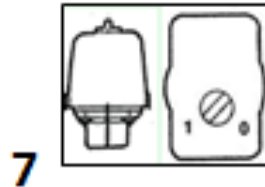
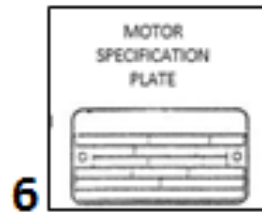
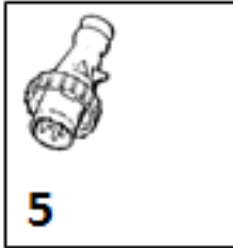
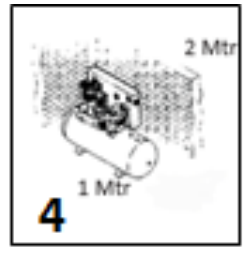
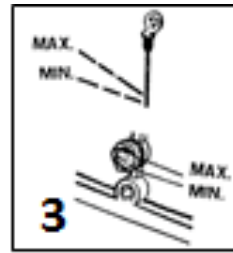
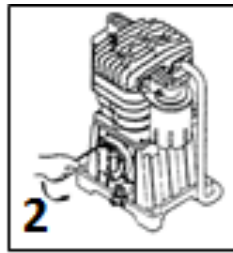
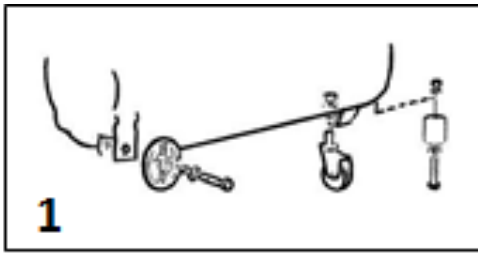

- 1. Base
- 2. Tank drain
- 3. Pressure relief valve
- 4. Belt guard
- 5. Compressor
- 6. Air filter
- 7. Drive belt
- 8. Electric motor
- 9. Pressure gauge
- 10. Air tank
- 11. Air outlet valve

2. INTRODUCTION.

Read this manual carefully before installing, using or carrying out any maintenance on your compressor.

This instruction manual has been written to simplify installation, maintenance and general use of your new compressor. Strict observance to the content of this manual is essential to ensure a correct and economical operation of the compressor.

The “Warning” notes, underline those operations which, if not carried out correctly could cause damage to the equipment and injury to the user.

We strongly recommend only genuine Hyundai replacement spare parts are used, which will guarantee the efficiency and service life of the compressor.

N.B. Warning

Use of non-genuine parts invalidates our warranty on your compressor.

INSTALLATION.

Having removed the compressor from its packaging and check that it is in perfect condition; you are now ready to install your new compressor as follows:

2.1 Portable compressors.

Fit the wheels and rubber foot as required (Fig 1).

Continue as stationary.

2.2 Stationary compressors.

2.2a Site the compressor on a level surface in a clean dry area (Fig 4). It is essential the compressor should have a 1 metre clearance from the surrounding walls and 2 metres from the ceiling to ensure proper ventilation and efficient cooling. If the compressor is sited in a small room there must be a minimum of two air changes per min to provide adequate ventilation. To achieve this it may require the use of both an input and extract fans to ensure the room temperature does not exceed 40°C.

2.2b It is further recommended that compressors used for painting be located in a separate room, away from the area where sanding/grinding and painting is done. Abrasive particles or paint found to have clogged the air intake filter and valves shall automatically void warranty.

N.B. Minimum Working temperature +5°C

2.2c Compressors that are receiver mounted or skid-base packages should not be bolted to the floor but installed on anti-vibration mounts. When using anti-vibration mounts it is essential to use a flexible pipe to connect the compressor to the installed system.

2.2d Air leaks if not corrected will cause excess wear in the compressor and can result in the compressor not being able to provide the air required.

3. ELECTRICAL NOTES.

3.3 Always use a qualified electrician to connect the compressor to the mains. Check electrical supplies match compressor specification as per the motor information plate (fig 6).

3.4 All compressors are supplied with a power cable of 2 metres for connection to a fused isolator close to the compressor. (not supplied) sited close to the compressor.

3.5 Single phase compressors can be fitted with an appropriate plug (Fig 5) & (Table 1). It is extremely important that attention is paid to the technical data sheet to establish the correct fuse and plug are used for the particular compressor in question.

N.B. Warning

Failure to use the correct plug and fuse could cause damage to the equipment and injury to the user, and will invalidate the warranty.

Three phase 2hp to 7.5hp compressors are fitted with a direct on line starter/pressure switch complete with 2 metres of cable for connection to a fused isolator (not supplied).

A 10hp three phase compressor is supplied with a star-delta starter, which is pre-wired with 2 metres of cable. The starter should be connected to a fused isolator (not supplied).

TABLE 1	HP	Supply voltage	Fuse / Plug type
	2-3*	230/1/50	13 amp flat 3 pin - EEC282
	3-4	230/1/50	32 amp 3 pin - EEC282
	2-3-3.5-4	400/3/50	16 amp 4 pin - EEC282
	5.5-7.5-10	400/3/50	32 amp 4 pin -

* Only compressors fitted with soft start and low current motors can be used with 13 amp plugs.

TANDEM/DUPLEX COMPRESSORS

- Installation for these compressors requires a qualified electrician to connect the compressor to the mains.
- Both tandem and duplex compressors (two pumps on same receiver) are supplied with a timed starter to make sure that there is a time lapse between each compressor starting.

4. INSTALLATION.

Secure starter panel (when supplied) to the wall or a fixed support and connect to a fused isolator adjacent to the control panel, or connect power cable direct to fused isolator (not supplied). Cable to the isolator should be suitable for the total HP/Kw been used (see Table 2). If an extension to the supply is required, it should have a cross section for the wires in proportion to its length, (see Table 2).

VALID SECTION FOR A MAXIMUM LENGTH OF 20 METRES

TABLE 2	HP/kw	220/230 Volt	380/400 Volt
	2-3-3.5/1.5-2.2-2.6	2.5 sq mm	1.5 sq mm
	5.5/4		2.5 sq mm
	7.5/5.6		2.5 sq mm
	10/7.5		4.0 sq mm
	20/15		10 sq mm

N.B. Warning any extension of supply cable should not be less in section than the cable fitted to the compressor by the factory.

CAUTION

Never use the ground clamp in place of the neutral clamp to provide a single phase supply. Earthing connections must be carried out in accordance with the safety regulations (EN60204). The power cable plug or socket/isolator must not be used to stop the compressor, as this could cause damage to the compressor when restarting. Always stop compressor via the pressure switch (Fig 7) on/off button.

Always use a suitably fused isolator sited close to the compressor. The isolator should preferably be fitted with a trip to avoid damage to the motor due to the loss of a phase.

The compressor pump and delivery pipe can reach very high temperatures. Use extreme caution when working in the proximity of these parts. To avoid burns, do not touch these parts (Fig 11).

5. START UP.

5.1 Compressors with DOL & Star/delta starters (Single/Three Phase).

5.1a Check that the line voltage corresponds to the motor data plate (Fig 6), tolerance must not exceed + or - 5%.

5.1b Turn switch on pressure switch to position "O" (OFF) (Fig 7). Connect to mains and switch power on.

5.1c Turn switch on pressure switch to position "1" (ON) (Fig 7). Compressor will now start. The pressure switch will automatically control the stopping and starting of the compressor to the factory standard settings.

5.1d Check the rotation of the compressor as this is of particular importance to ensure the correct cooling and lubrication of the compressor. See arrow on motor and fly wheel. (Fig 12).

N.B. Warning Because an automatic pressure switch controls the compressor, the compressor will start without warning.

5.2 Compressors with tandem and duplex starters.

5.2a Turn switch on pressure switch to position "O" (OFF) (Fig 7).

5.2b Select the duty cycle by turning the control knob to the required setting (Fig 9).

5.2c Turn switch on pressure switch to position "1" (ON) (Fig 7). Compressor will now start and be controlled in accordance with the duty selected. The pressure switch will automatically control the stopping and starting of the compressor to the factory standard settings.

Position 1	Only number one compressor runs
Position 3	Only number two compressor runs
Position 2	Both compressors run

N.B. Warning Because an automatic pressure switch controls the compressor, the compressor will start without warning.

5.3 Overload protection.

5.3a The single phase electric motors are equipped with an amperometric thermal cut-out with manual reset located on the terminal box at the top of the electric motor.

When the thermal cut-out intervenes, wait several minutes, then manually reset the thermal switch (Fig 12).

- With three phase compressors, the cut-out is automatic and is located inside the pressure switch. When the thermal cut-out intervenes, the pressure switch cuts-out and moves to the position “O” (OFF)(Fig 7), wait 10 minutes and turn the pressure switch back to position “1” (ON) (Fig 7).
- With compressors equipped with a wall mounted starter the thermal cut-out is located on the inside of the starter unit. When the thermal cut-out intervenes, turn the pressure switch to position “O” (OFF) (Fig 7), wait several minutes, then manually reset the thermal overloads.
- To Reset thermal overloads push the blue reset buttons on the front cover of the wall mounted starter unit.
- Restart the compressor by the steps described in the section “Start Up”

6. MAINTENANCE.

CAUTION Before performing any maintenance on the compressor make sure that:
The compressor is isolated from the electrical supply. The pressure switch and switches on the power unit are turned to position “OFF”.
The receiver is drained of any compressed air.

6.1 Cleaning and changing filter cartridge.

Clean the air intake filters every month by blowing compressed air from the inside of the filter to the outside of the filter or cartridge (Fig. 14).

We recommend replacing the filter cartridge or filter element at least twice a year if the compressor operates in a clean environment and more frequently if the compressor is located in a dusty environment.

6.2 General maintenance.

Check the tension of the belts every month and adjust them if necessary.

Release the condensate from the air receiver at least once a day by opening the discharge tap (Fig. 15).

Thoroughly clean all external parts of the compressor and motor every 6 months or 2000 running hours to ensure proper cooling.

6.3 Oil.

Check oil level every day (Fig. 3) when compressor is cold, top up as necessary. Use Hyundai 100 OIL or SAE10W/30 engine oil.

6.4 Oil change.

Remove the drain plug (Fig 16) to drain the oil and then re-fit drain plug. Top up to the appropriate oil level as (Fig 3). FIAC 100 oil should be changed every 6 months or 2000 running hours which ever is reached first. Alternatively you can use or SAE10W/30 engine oil, Oils other than FIAC 100 should be replaced every 3 months or 250 hours.

6.5 Emergency STOP button (TANDEM ONLY).

The emergency stop button (Fig17) is located on the wall-mounted starter this allows the compressor to be stopped in an emergency. **DO NOT USE THIS SWITCH AS A POWER SWITCH.** To reset the emergency button, rotate the red knob anti-clockwise a half turn. To restart the compressor refer to “START UP” (Page 4) relevant to your compressor.

6.6 How to fix minor faults.

6.6a Air leak from pressure switch valve. These are caused by air leaking from the receiver through the non-return valve.

6.7 How to fix it. (Fig. 18).

6.7a Empty the tank of compressed air completely.

6.7b Unscrew the hexagonal head of the valve (Fig. 18) (A).

6.7c Clean or replace the rubber disk (Fig. 18) (B) and clean the housing thoroughly.

6.7d Re-assemble the unit carefully.

6.8 The compressor runs but does not produce air.

6.8a Check the inlet and outlet valves (Fig. 19) and gasket for damage.

6.8b Replace damaged parts using Service Kit No.1.

WARNING

Never unscrew any joints with the air receiver under pressure, always ensure that the air receiver is empty of compressed air.

Do not work on the compressor without disconnecting the unit from the electrical power supply.

Ambient working temperature range +5°C to +40°C

Do not direct water or inflammable liquids towards the compressor.

Do not place inflammable objects near the compressor. Do not place any articles on or near the compressor, this will impede the cooling and could cause a fire.

When the compressor is not being used turn the pressure switch to the “OFF” position. (Fig. 7).

Never direct compressed air at persons or animals.

Do not transport the compressor with the tank under pressure.

Keep children and animals away from the area where the machine is operating.

After using the compressor always disconnect from the electrical supply.

6.9 If the compressor is used for painting.

6.9a Do not operate the compressor in closed spaces or in the proximity of naked flames and spray vapour.

6.9b Make sure that the room where you are working has a Sufficient change of air (Min 2 per minute, see installation notes). (Fig. 20).

6.9c Use an appropriate mask to protect nose and mouth (Fig. 20).

Compressed air receivers for the European market are built in accordance with EC Directive 09/105.

Air Compressors for the European market are built in conformity with the Directive 2006/42/EC

7. PRESSURE SWITCH ADJUSTMENTS.

NE-MA Single Phase

N.B. Warning

Switch off power at fused isolator before making any adjustment to the pressure-switch.

7.1 NE-MA pressure switch is supplied with a standard cut out pressure 150 psi and a cut in pressure of 120 psi.

7.2 The cut out setting can be adjusted to suit your individual requirement as follows:

7.1a Increase or decrease cut out pressure. Adjust (A) clock wise to increase, anti-clock wise to decrease (Fig 21).

N.B. Warning Pressure must not exceed maximum working pressure of the receiver.

NE-MA Fig 21

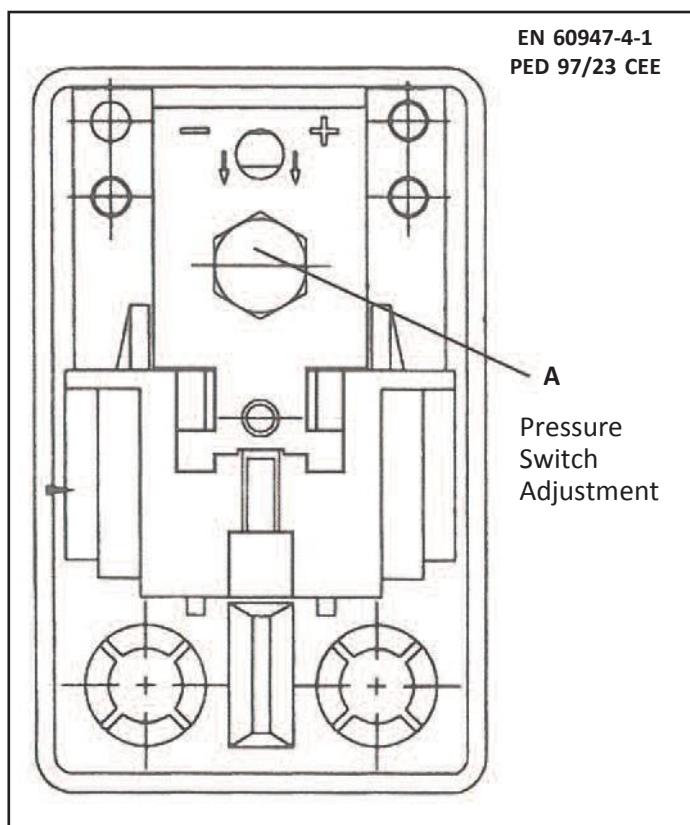

MDR-3 Three Phase

N.B. Warning Switch off power at fused isolator before making any adjustment to the pressure-switch.

7.3 MDR-3 pressure switch is supplied with a standard cut out pressure 150 psi and a cut in pressure of 120 psi.

7.4 Both these settings can be adjusted to suit your individual requirement as follows:

7.4a Increase or decrease cut out pressure. Adjust the central upper pressure screw (A) clockwise to increase or anti-clockwise to decrease (Fig 23).

7.4b Increase or decrease differential pressure. With a screwdriver adjust the pressure differential screw (B) clockwise to increase, anti-clock wise to decrease (Fig 23).

Note: From time to time the pressure switch settings may vary and should be adjusted as per above (This is NOT covered by warranty).

MDR 3 Fig 22

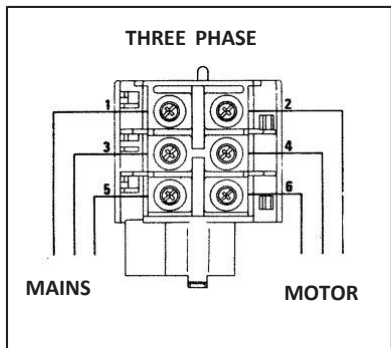

MDR 3 Fig 23

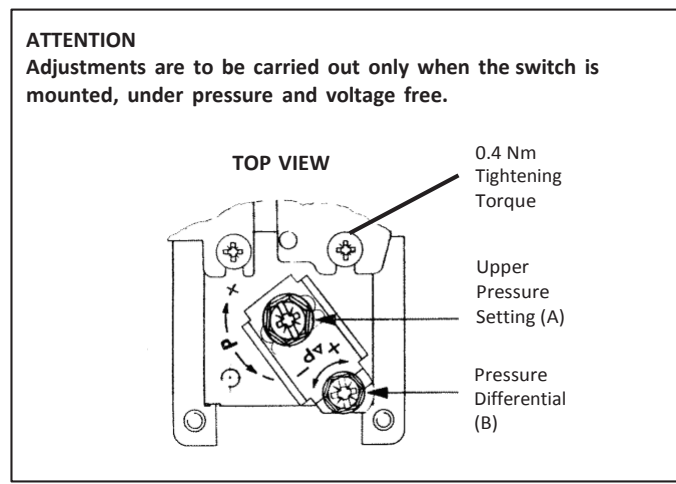

8. ELECTRICAL CONNECTIONS.

ELECTRIC MOTOR TERMINAL BOARD CONNECTION

230/50/1 MOTORS

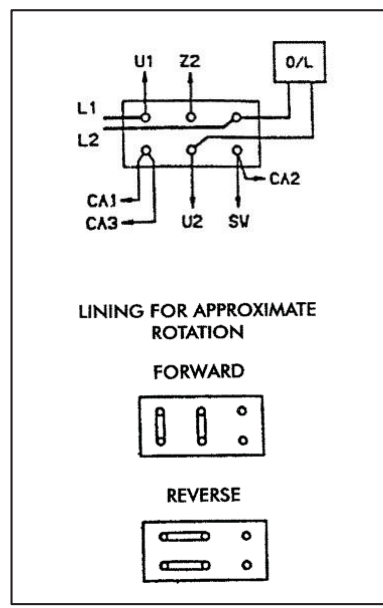

400/50/3 MOTORS STAR DELTA

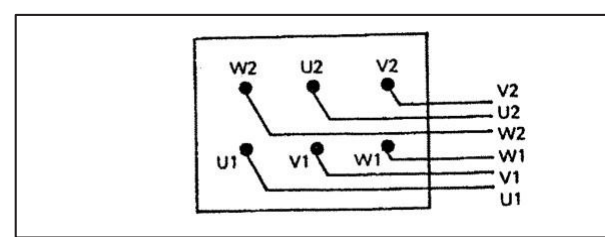

400/50/3 MOTORS D.O.L.

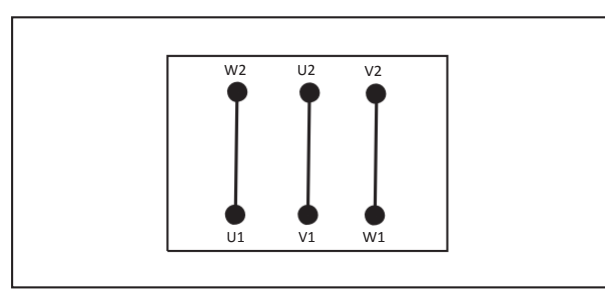

STAR DELTA 400/50/3

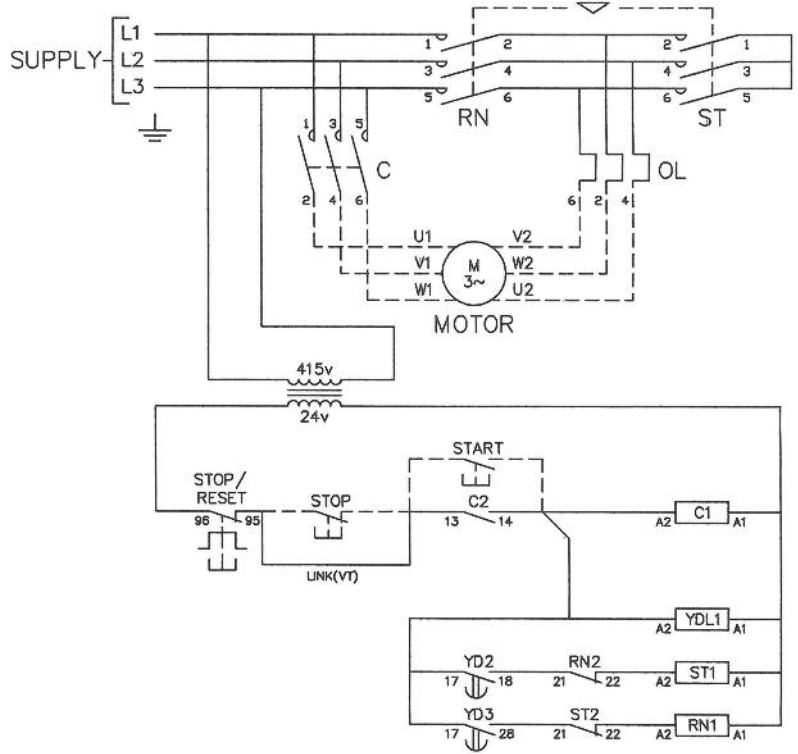
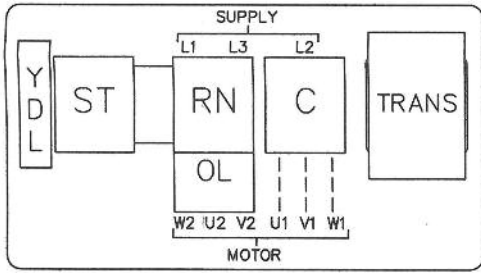
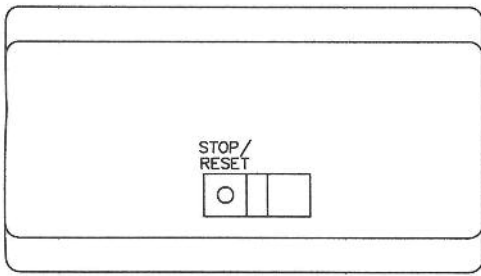

TANDEM STARTER CIRCUIT DIAGRAM 230/50/1

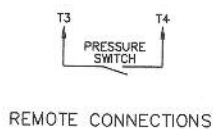
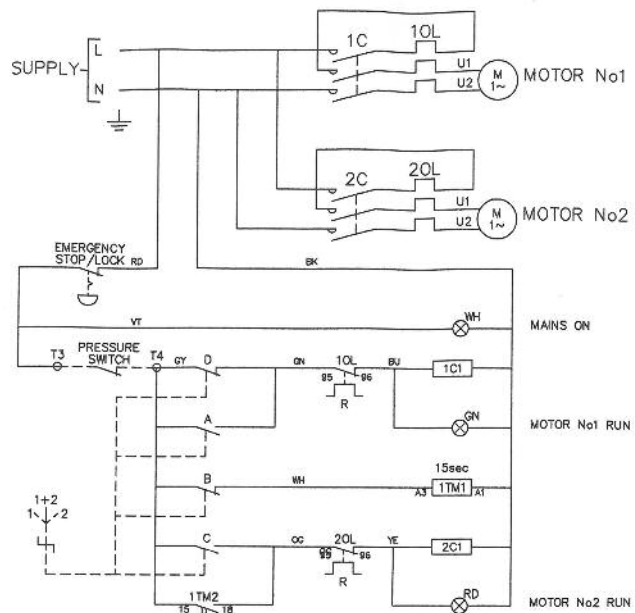
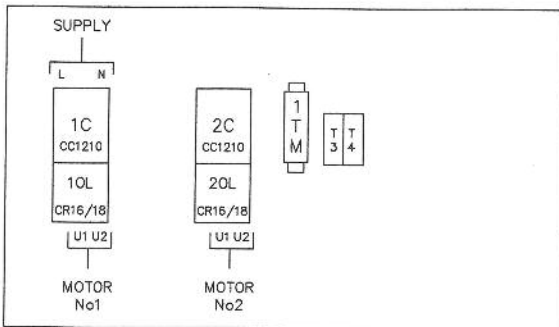
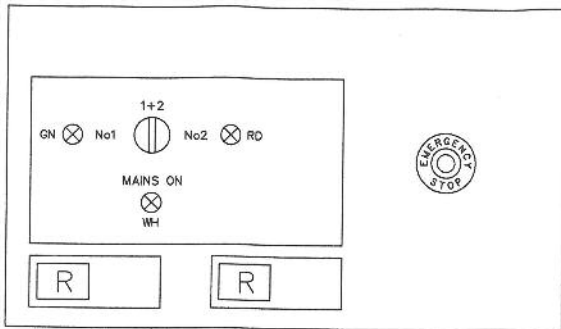

REAR VIEW OF SWITCH

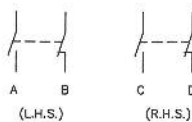

		CONTACT POSITION			
		A	B	C	D
SWITCH POSITION	1	X			X
	1+2		X		X
	2			X	X

SELECTOR SWITCH ARRANGEMENT.

9. SPECIFICATIONS.

Model	HY55200-3	HY75270-3
Voltage - V	400	400
Number of phases	3	3
Frequency – Hz	50	50
Connection method/Cable length m	Hard wired - 3 pin + earth industrial plug	Hard wired - 3 pin + earth industrial plug
Motor power hp/kw	5.5/4	7.5/5.6
Rated Speed (motor) – RPM	2800	2800
Maximum Pressure - PSi/Bar	145/10	145/10
Cut-out Pressure - PSi/Bar	120/8.3	120/8.3
Cut-in Pressure - PSi/Bar	87/6	87/6
Tank Capacity - L	200	270
Free air delivery - CFM - L/min	16.5/476	21/595
Displacement - CFM/L/min	23/651	29/821
Air Outlet	Valve Tap/½" BSP	Valve Tap/½" BSP
Output pressure regulation type	Fixed	Fixed
Drive type	Belt	Belt
Overall Unit Dimensions L x W x H mm	1520 x 480 x 940	1600 x 500 x 1040
Net Weight - kg	126	135
Tank material	Rolled steel	Rolled steel

10. DECLARATIONS of CONFORMITY.

Compressor models **HY55200-3 & HY75270-3**

Designed & produced in accordance with the following

- Machinery Directive 2006/42/EC
- Supply of Machinery (Safety) Regulations 2008
- Supply of Machinery (Safety) Amendment Regulations 2011
- EU Directive 2000/14/EC (2005/88/EC)

Apply to air receiver:

- Simple Pressure Vessels Directive 2009/105/EC
- Simple Pressure Vessels (Safety) Regulations 1991
- Simple Pressure Vessels (Safety) Amendment Regulations 1994
- EN286-1 Unfired Pressure Vessels

Apply to safety valve:

- Pressure Equipment Directive 1997/23/EC
- The Pressure Equipment Regulations 1999
- ISO 4126;.1 Safety Valves Part 1

11. DECLARATIONS of CONFORMITY.



Products which are labelled with the adjacent symbol **MUST NOT** be disposed of in household rubbish. You must dispose of packaging and old electrical and electronic equipment separately.

11.1 Disposing of packaging.

10.1.1 The packaging consists of cardboard and correspondingly marked plastics that can be recycled.

10.1.2 Recycle all packaging materials.

11.2 Disposing of appliance (at end of life).

10.2.1 Please check with your local authority about the possibilities for correct disposal.



GENPOWER LTD

Isaac Way, Pembroke Dock, Pembrokeshire, UK, SA72 4RW

T: +44 (0) 1646 687880

F: +44 (0) 1646 686198

E: sales@genpower.co.uk

www.hyudaipowerequipment.co.uk