

# HYUNDAI

## WHEELED TRIMMER

Model HYWT5080



## User Manual

---

Licensed by Hyundai Corporation, Korea



## CONTENTS

1.	SAFETY	4 - 7
2.	QUICK START	8 - 16
3.	STARTING PROCEDURE	17 - 18
4.	STOPPING PROCEDURE	19
5.	USING THE MACHINE	20
6.	MAINTENANCE	21 - 24
7.	TROUBLESHOOTING	25
8.	SPECIFICATION	26
9.	PART LOCATIONS	27
10.	DECLARATIONS OF CONFORMITY	28
11.	RECYCLING & PRODUCT DISPOSAL	29
12.	CONTACT DETAILS	29
13.	MANUAL UPDATES	29
14.	WARRANTY	30

# 1. SAFETY

## 1.1. General safety notes.

1.1.1. The operator of the machine is responsible for, and has a duty of care in making sure that the machine is operated safely and in accordance with the instructions in this user manual. Keep the manual safe and pass it on if the machine is loaned or sold to another user.

1.1.2. Please note the following safety points.

1.1.2.1. The machine should never be left in a condition which would allow an untrained or unauthorised person/s to operate this machine.

1.1.2.1.1. All due care and diligence should be taken by the operator for the safety of, and with regard to those around whilst using the machine.

1.1.2.1.2. Some or all of the following - warning signs, symbols and/or PPE pictograms may appear throughout this manual. You MUST adhere to their warning/s. Failure to do so may result in personal injury to yourself or those around you.

### **DANGER**

Indicates a hazard, which, if not avoided, could result in serious injury or death.

### **WARNING**

Indicates a hazard, which, if not avoided, could result in serious injury.

### **CAUTION**

Indicates a hazard which, if not avoided, might result in minor or moderate injury.

### **NOTE**

Indicates a situation that could easily result in equipment damage.



READ and keep the manual safe and pass it on if the machine is loaned or sold to another user. You MUST fully read instructions to make sure you use and operate machine safely.

Appropriate Personal Protective Equipment (PPE), MUST be worn at all times when Machine is in use or being repaired.



**⚠ DANGER!**

**BREATHING IN CARBON MONOXIDE FUMES CAN KILL YOU!**  
To help protect against CO poisoning install a Carbon Monoxide detector.

**NEVER** use Petrol/Diesel powered equipment inside, especially a home, garage, tent, camper-van, caravan, motorhome or boat.  
**EVEN** if doors, windows, vents and hatches are open. Only use **OUTDOORS** and as far away from doors, windows, vents and open hatches as possible to prevent inhaling fumes.

READING MANUAL BEFORE USE WILL HELP AVOID OTHER MACHINE HAZARDS.

1.2. Carbon monoxide (where applicable).

1.2.1. Carbon monoxide is a colourless and odourless gas. Inhaling this gas can cause death as well as serious long term health problems such as brain damage.

1.2.2. The symptoms of carbon monoxide poisoning can include but are not limited to the following; Headaches, dizziness, nausea, breathlessness, collapsing or loss of consciousness.

1.2.2.1. Carbon monoxide poisoning symptoms are similar to flu, food poisoning, viral infections and simply tiredness. It is quite common for people to mistake this very dangerous poisoning for something else.

1.2.2.2. To avoid carbon monoxide poisoning DO NOT use Petrol/Diesel- powered equipment inside any of the following; Home, garage, tent, camper van, mobile home, caravan or boat.

This list is not exhaustive and if you are in any doubt contact your dealer.

1.2.3. If you think you have or someone around you has been affected by carbon monoxide poisoning;

1.2.3.1. Get them fresh air immediately, by leaving the affected area or by opening doors and windows. If safe and practical to do so

make sure that the machine is turned off. DO NOT enter a room you suspect of having carbon monoxide present – instead call the emergency services.

1.2.3.2. Contact a doctor immediately or go to hospital - let them know that you suspect carbon monoxide poisoning.

1.2.4 DO NOT use in an enclosed area or a moving vehicle.

1.3. General fuel safety (where applicable).



ALL FUELS ARE FLAMMABLE

1.3.1. Fire hazard - keep fuel away from all sources of ignition for example heaters, lamps, sparks from grinding or welding.



Fire Hazard

1.3.2. DO NOT carry out hot work on tanks that have contained fuel it is extremely dangerous.

1.3.3. ALWAYS keep work area clean and tidy.

1.3.4. ALWAYS clean up all spills promptly using correct methods i.e. absorbent granules and a lidded bin.

1.3.5. ALWAYS dispose of waste fuels correctly.

1.4. Fueling/De-fueling (where applicable).



ALL FUELS ARE FLAMMABLE

1.4.1. ALWAYS fuel and defuel in a well-ventilated area outside of buildings.

1.4.2. ALWAYS wear correct, suitable and fit for purpose Personal Protective Equipment (PPE), suggested items are but not limited to safety gloves and overalls.



1.4.3. When fueling/de-fueling ALWAYS avoid inhaling fumes

1.4.4. When de-fueling ALWAYS use a proprietary fuel retriever.

1.4.5. ALWAYS carry fuel in the correct and clearly marked container.



Fire Hazard

1.5. Electrical safety (where applicable).



Risk of electric shock

1.5.1. Electricity can kill - NEVER work on LIVE/ENERGISED equipment.

1.5.2. Prior to carrying out any maintenance work you MUST Identify electrical isolation methods and isolate all electrical supplies,

1.5.3. Prior to use and with all electrical supplies isolated You MUST check all electrical cables, plugs and connections for the following;

1.5.3.1. Are intact and have no signs of damage, to include but not limited to bare wires, chaffing, cuts and loose wiring.

1.5.3.2. If there are any signs of damage, the damaged item MUST be taken out of service until the damage has been repaired by an electrically competent person.

1.5.3.3. All trailing cables should be routed so as not to cause any kind of trip hazard.

1.5.3.4. NEVER work on or near electricity with wet hands, wet clothing, and wet gloves.

1.6. Batteries (where present).



Corrosive

1.6.1. Batteries present a risk if they become damaged by the possible leaking of electrolyte. This electrolyte is an acid and can cause serious burn injuries. Care should be taken when working on or near them. NOTE the electrolyte may be in liquid or gel form.

1.6.2. Should you come into contact with electrolyte you should;

1.6.2.1. Remove all clothing contaminated with electrolyte. If you cannot remove then saturate in water.

1.6.2.2. Get medical assistance as soon as possible. You must advise the medical staff of the type acid.

1.6.2.2.1. Lead/acid battery = dilute sulphuric acid

1.6.2.2.2. Nickel/cadmium = potassium hydroxide alkali electrolyte.

1.6.2.3. Use fresh running water to wash off excess electrolyte, continue this until medical assistance arrives. Make sure that you do not wash the electrolyte to another part of the face or body.

1.6.2.4. If electrolyte comes into contact with Eyes the electrolyte needs to be immediately washed away with large amounts of water. Make sure that you do not wash the electrolyte to another part of the face or body.

1.6.3. Gasses from charging batteries are highly flammable and great care should be taken to charge in well ventilated areas.

1.6.4. There is an explosion risk if the battery terminals are short circuited, when connecting/dis-connecting ALWAYS exercise great care so that the terminals or battery leads are NOT allowed to touch and cause a spark. ALWAYS use suitable insulated tools.



1.7. Vibrations (where applicable).

1.7.1. Prolonged use of hand held (operated) machines will cause the user to feel the effects of/from vibrations. These vibrations can lead to white finger (Raynaud's phenomenon) or carpal tunnel syndrome. This condition reduces the ability of the hand to feel and regulate temperature, causing numbness and heat sensations and may cause nerve damage and circulatory tissue death.

1.7.2. Not all factors that lead to white finger

disease are known, but cold weather, smoking and other diseases that affect blood vessels and blood circulation as well as large and long-lasting impact of shocks are considered factors in the formation of white finger. Note the following to reduce the risk the white finger and carpal tunnel syndrome:

1.7.2.1. Wear gloves and keep your hands warm

1.7.2.2. Take regular breaks

1.7.3. All of the above precautions may help reduce the risk of white finger disease but not rule out carpal tunnel syndrome. Long-term and regular users are therefore recommended to observe the condition of your hands and fingers. Seek medical attention immediately if any of the above symptoms should occur.

1.8. Noise (where applicable).

1.8.1. The operating noise of the machine can damage your hearing. Wear hearing protection such as earplugs or ear defenders to protect your hearing. Long-term and regular users are advised to have hearing checked regularly. Be especially vigilant and cautious when wearing hearing protection because your ability to hear alarm warnings will be reduced.

1.8.2. Noise emissions for this equipment is unavoidable. Carry out noisy work at approved times and for certain periods. Limit the working time to a minimum. For your personal protection and protection of people working nearby it is also advisable for them to wear hearing protection.

1.8.3. See CERTIFICATE of CONFORMITY section for Outdoor Noise declaration of conformity.



### 1.9. Additional safety labels.

Keep all children, bystanders and helpers 15 meters from the machine.



Warning against flying objects wear helmet, goggles and ear protection.



Warning: Danger from hot components, especially exhaust - Keep clear of combustible materials.



### 1.10. Additional safety instructions.

1.10.1. This machine may only be used for trimming grass. NEVER use for other purposes, as this may result in serious injury! Safety instructions must be observed. DO NOT EXPOSE YOURSELF OR OTHERS TO THE RISKS. Follow these general instructions -

- ALWAYS wear safety goggles for eye protection.
- Long hair must be tied back.
- DO NOT wear loose clothing or jewelry that could get caught in moving parts of the machine. Safe, strong, non-slip safety shoes should be worn.
- It is recommended that the legs and feet are fully protected, to protect themselves during the operation against flying objects.

1.10.2. Check the entire machine for loose/missing parts (nuts, bolts, screws, etc.). Tighten/ replace before using the machine. DO NOT use accessories with this machine other than those recommended/supplied by the manufacturer. Otherwise serious injuries to the user or bystanders as well as damage to the machine will result.

 **DANGER** NEVER use the machine with a saw blade attachment it is STRICTLY FORBIDDEN.

- Keep the handles free of oil and fuel.
- ALWAYS use the correct interface handles and shoulder strap.
- DO NOT smoke when mixing fuel or when filling the tank.
- DO NOT mix fuel in an enclosed area or near open fires.
- Make sure there is sufficient ventilation.
- Mix and store the fuel mixture in a correctly marked container, which is allowed by local regulations.

1.10.3. During and after use the engine and exhaust will be very HOT you must keep all your all parts of your body and clothing including all combustible materials clear of the engine and exhaust.

1.10.4. DO NOT use the machine during or after rain, snow or sleet. The floor will become slippery. DO NOT use the machine on a slope or uneven ground or if there is the chance of slipping or losing the stability.

1.10.5. If you trip or fall whilst machine is in use you MUST immediately release the throttle, and turn off the ignition switch.

1.10.6. If you hit any obstacles you must stop the machine and remove the HT lead so that you can inspect the machine. IF the machine is damaged in any way you MUST get it repaired before restarting work.

1.10.7. DO NOT use a damaged machine or a machine with a blunt, cracked or damaged cutter blade or trimmer head.

1.10.8. If any trimmed materials get tangled in the nylon cord or cutting blade you MUST stop the machine and remove the HT lead. Only then can you clear any blockages.

1.10.9. DO NOT wear rings and jewelry or loose, dangling clothing that could get caught in the machine. DO NOT wear footwear with unprotected toes and DO NOT work barefoot or without leg protection. In certain situations, you have to wear head protection.

1.10.11. DO not use the brush cutter for trimming trees.

## 2. QUICK START

You can also check out our online video at [www.youtube.com/hyundaipowerequip.co.uk](http://www.youtube.com/hyundaipowerequip.co.uk)

2.1. This guide is meant to serve as a quick reference for operating your Hyundai Wheeled trimmer it is for convenience and the user should read the safety section first.

### FOR OUTDOOR USE ONLY.

This Wheeled trimmer produces carbon monoxide - a poisonous, colourless & odourless gas that can cause death or serious injury. Petrol is highly flammable, always handle with extreme care and in a well ventilated area.

Always remove HT lead from spark plug when checking machine or changing parts.

2.2. This product includes, Main unit, Operators handle, Trimmer head shaft, Trimmer head, Spare 2.5 mm nylon cord, Full harness, Gloves, Face shield, Ear defenders, Tool kit, Spare spark plug, 2-Stroke oil mixing bottle, User manual, Warranty registration form.

2.3. At this point, check that you have all of the included items listed above. If any are missing or damaged, call 01646 687 880 or email [info@hyundaipowerequipment.co.uk](mailto:info@hyundaipowerequipment.co.uk).

2.4. Handle assembly.

Take the 3 handle fixing bolts from the tool kit bag



Unfold the handle bars as shown in following images

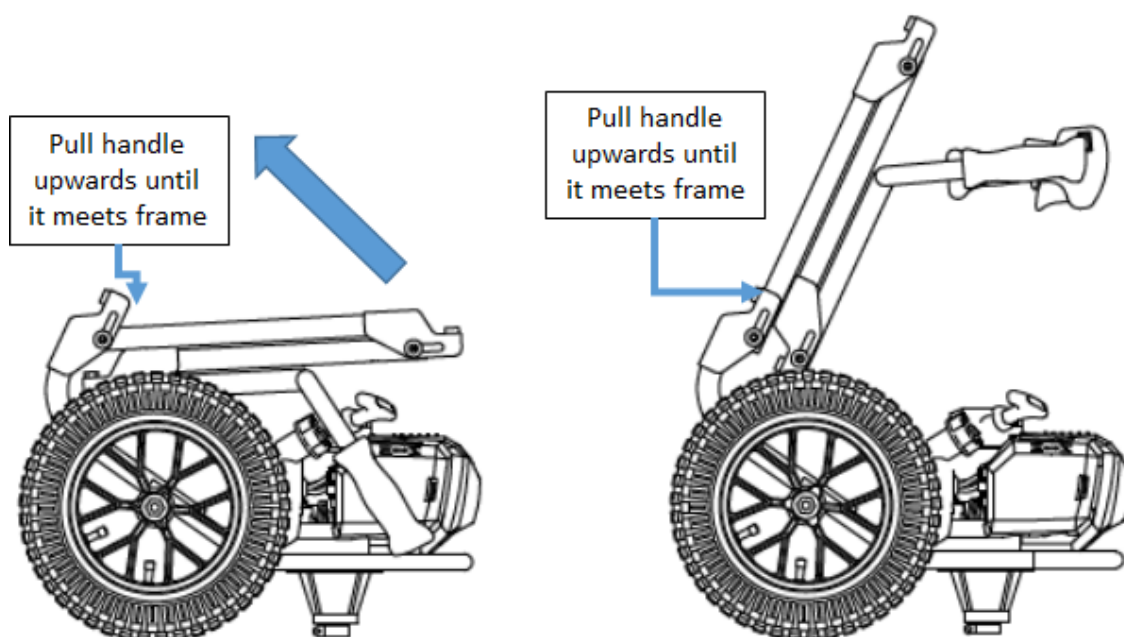



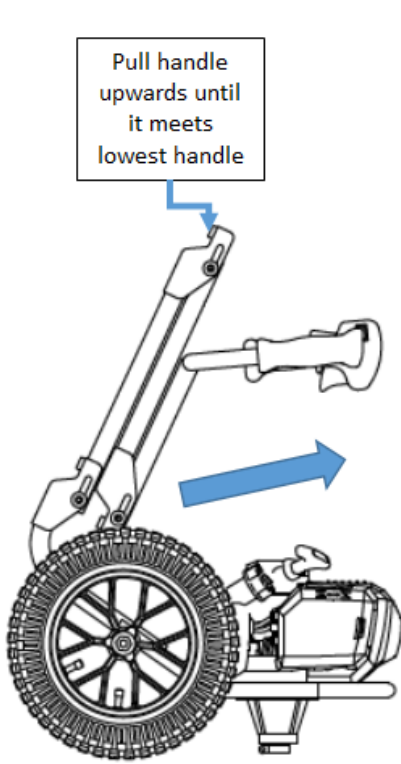

Pull handle upwards until it meets lowest handle

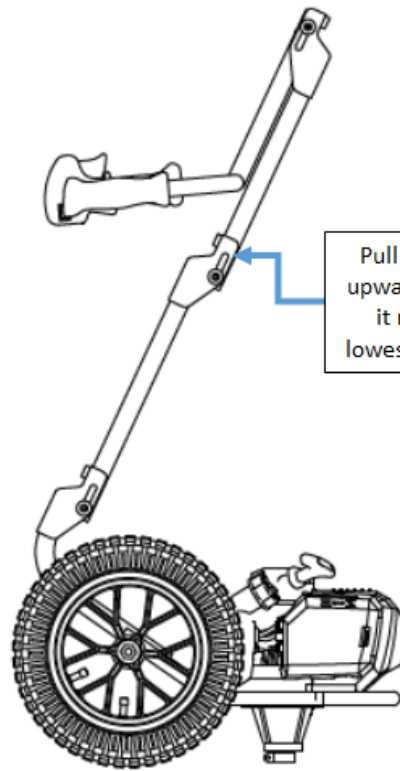

Pull handle upwards until it meets lowest handle

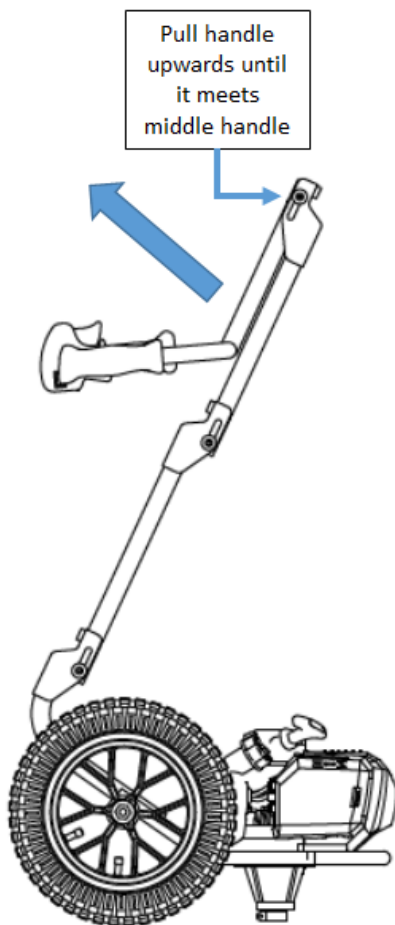

Pull handle upwards until it meets middle handle

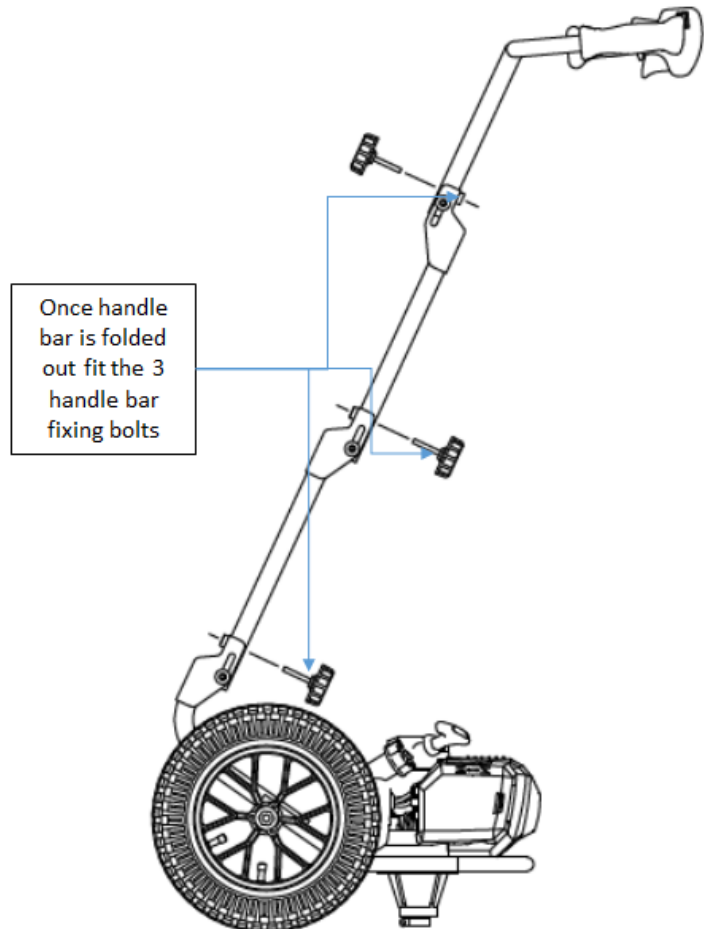

Once handle bar is folded out fit the 3 handle bar fixing bolts

Screw handlebar bolts (clockwise) in each section of handle as shown in image below.



## 2.5. Cord cutter assembly.

Take the cutter guard from the box and the cord cutter from the tool kit bag along with the two cutter blade nuts/bolts. You are advised to wear safety gloves to prevent injury. Pass the bolts through the blade and then through the cutter guard into the locknuts on the other side – once both nuts and bolts have been fitted make sure they are fully tightened.

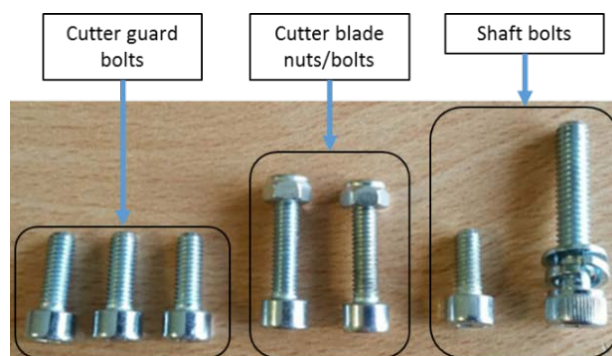
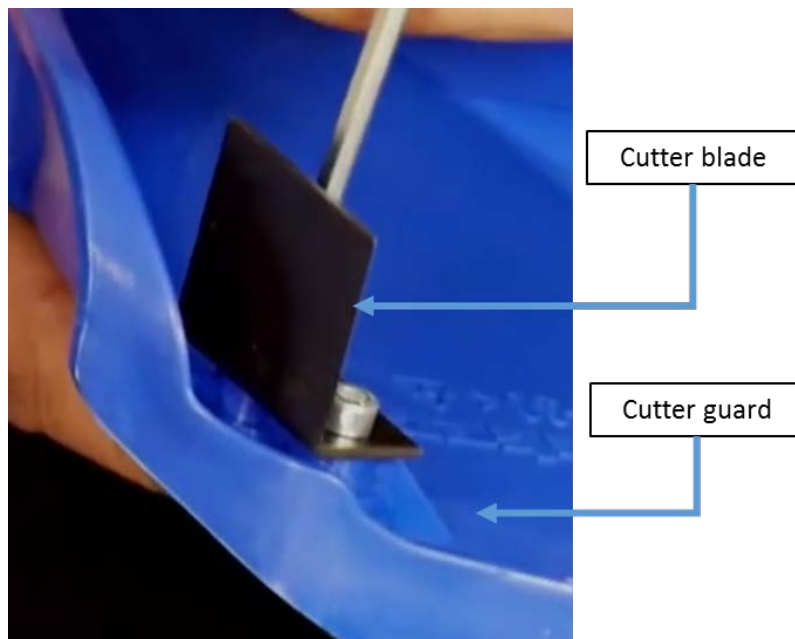

2.6. Attaching cutter guard to the shaft assembly.

Take the cutter guard and place it over the shaft, then using the three cutter guard bolts and the spacer ring. Fix the guard to the shaft assembly. Tighten the three bolts using the supplied Allen key.

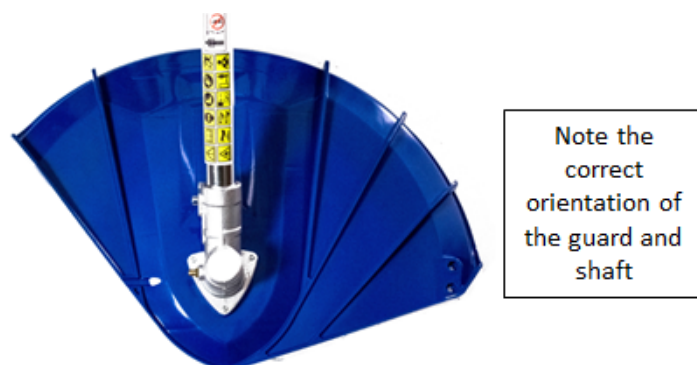
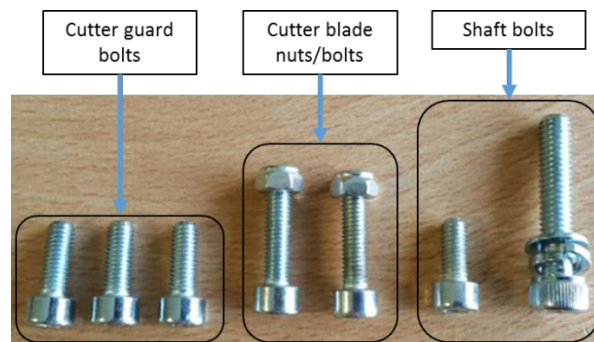
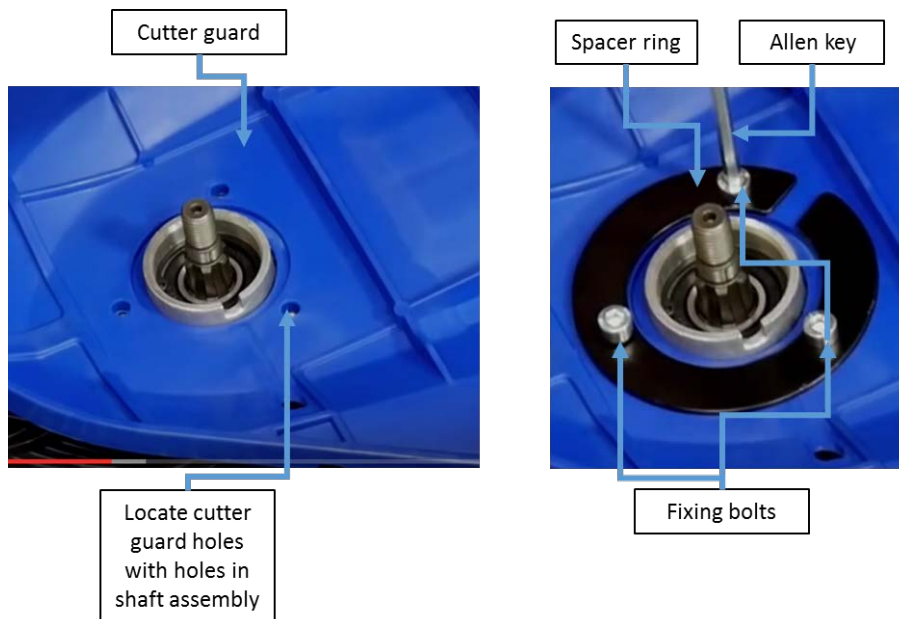

2.7. Installing/Replacing cutting cord.

Take the cutter head and cut 2 x 270mm lengths of cutting cord. Push one piece of cutting cord and push it into the head as shown below. Repeat for the other side. Any excess cord will be cut off by the cored cutter on the shield when first used.

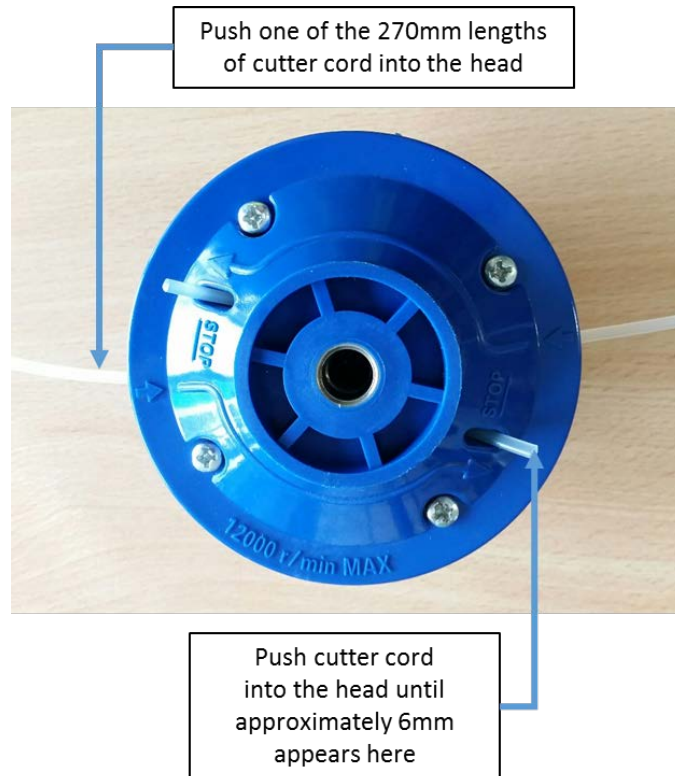

2.8. Trimmer head assembly – NEVER use a saw blade with this machine.

Take spacer from the tool bag and place it over the shaft, then using the one of the supplied Allen keys lock the shaft and spacer.

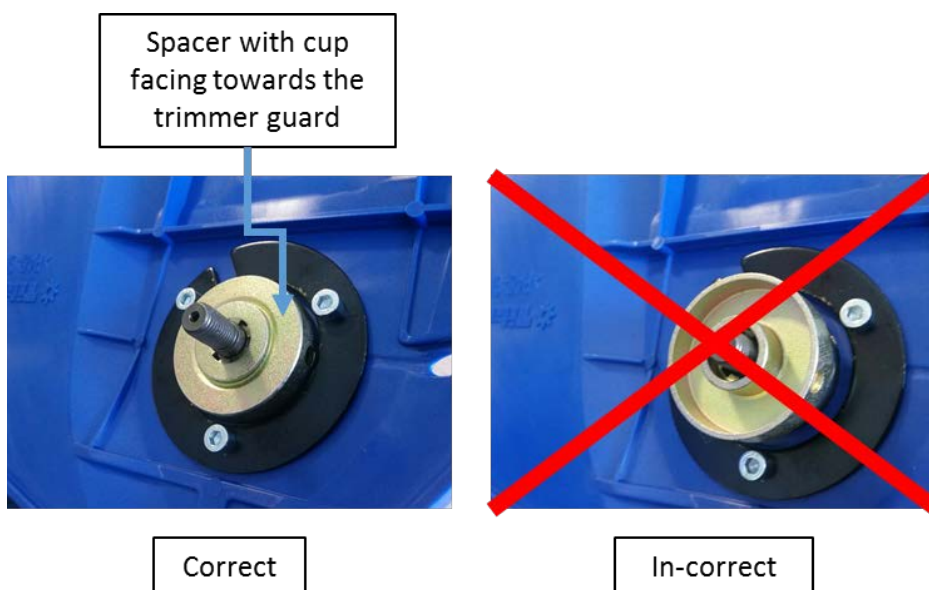

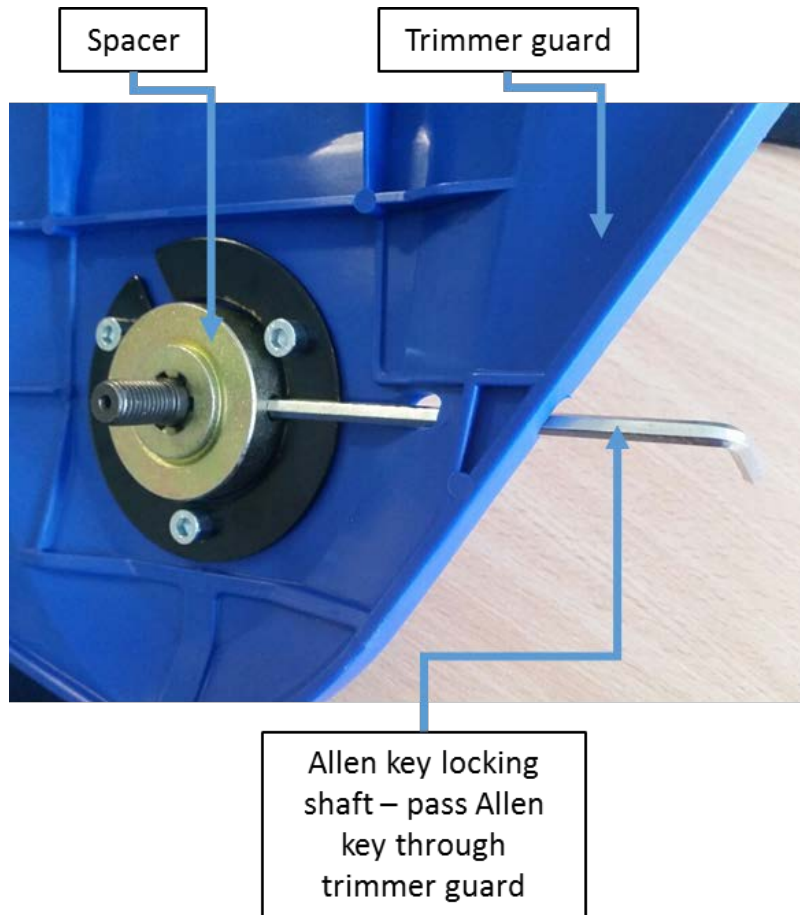

Take the trimmer head and screw it onto the shaft in an anti-clockwise direction until fully tightened.  
Remove the Allen key before use.

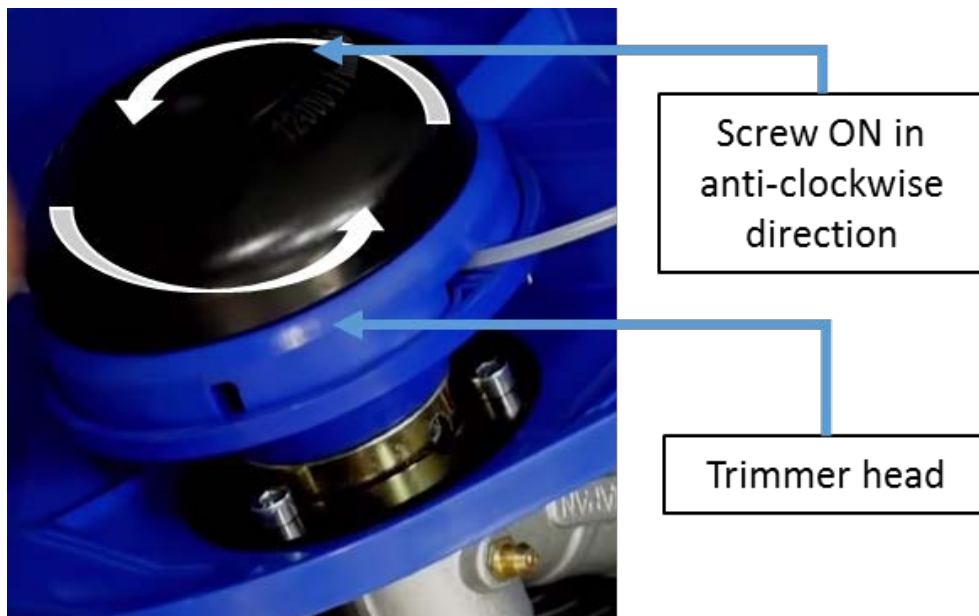

## 2.8. Head assembly.

Take the shaft assembly and push it into the drive shaft hole. N.B. you will need to remove the transit bung. Keep the bung safe for use when machine is stored. Make sure to align the hole on the shaft with the hole on the drive shaft. Once aligned screw and tighten the shorter of the two shaft bolts and then tighten the longer shaft bolt until it is fully tightened. You may have to rotate the shaft to align holes and drive.

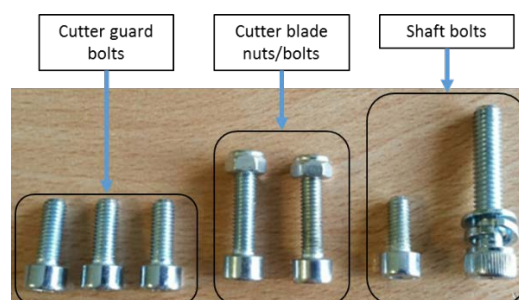
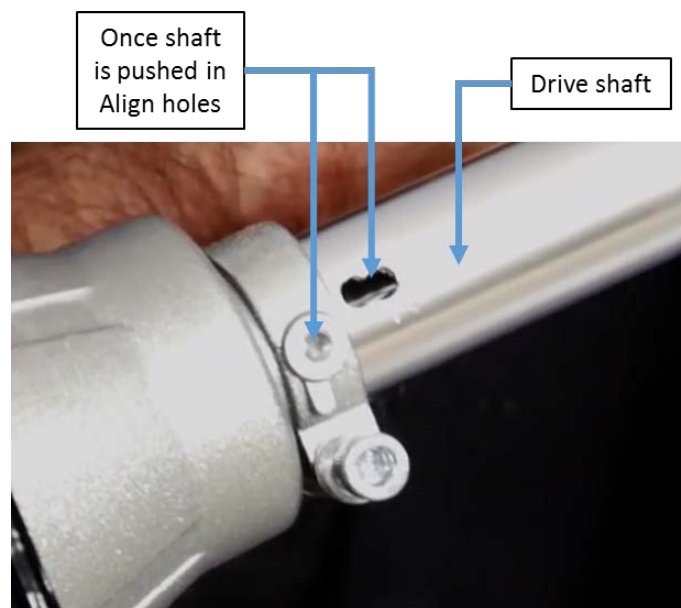
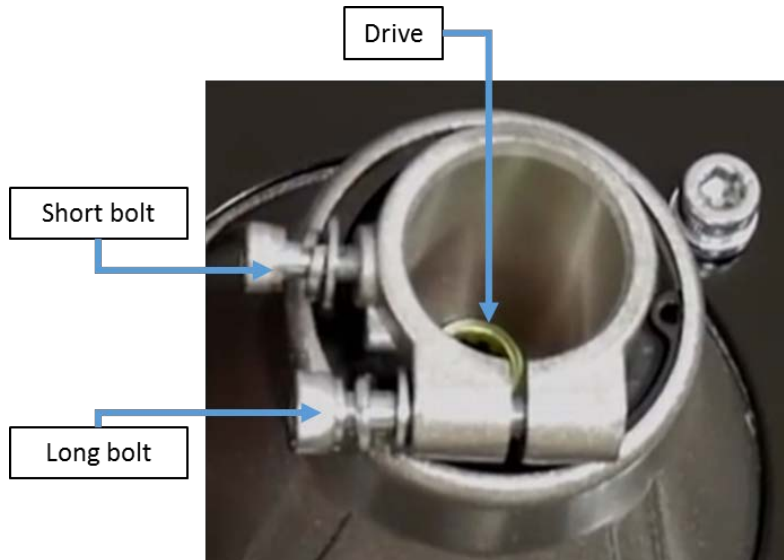

## 2.9. Head shield/Ear defender assembly.

Rotate to align the tags on the helmet to match the holes on the top of the visor. Place the visor over the tags, then rotate the tags 180° to secure into place. Place the ear defenders over the outside of the head band on the helmet and place into the clips.



## 2.10. Mixing 2 stroke oil.

Fill the mixing bottle with fresh unleaded petrol to the fuel marker line use a 40:1 ratio. Then top up with 2 stroke oil to 40:1 ratio line shake until fuel/oil has mixed.

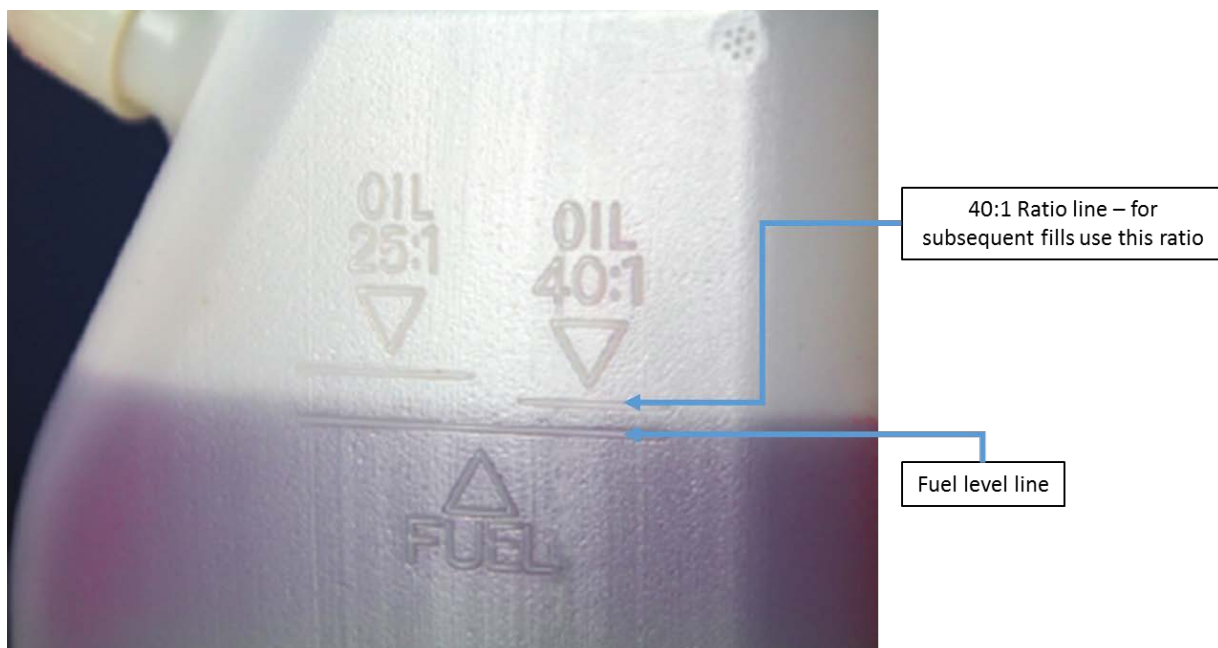

## 2.11. Adding fuel.

Unscrew the fuel tank cap and carefully add a 2-stroke fuel/oil mixture as in section 2.10. DO NOT overfill and allow a 25 mm gap at the top of the tank. Once full replace and correctly tighten the fuel cap. Fuel tank capacity is 1200ml.

DO NOT use straight unleaded petrol.

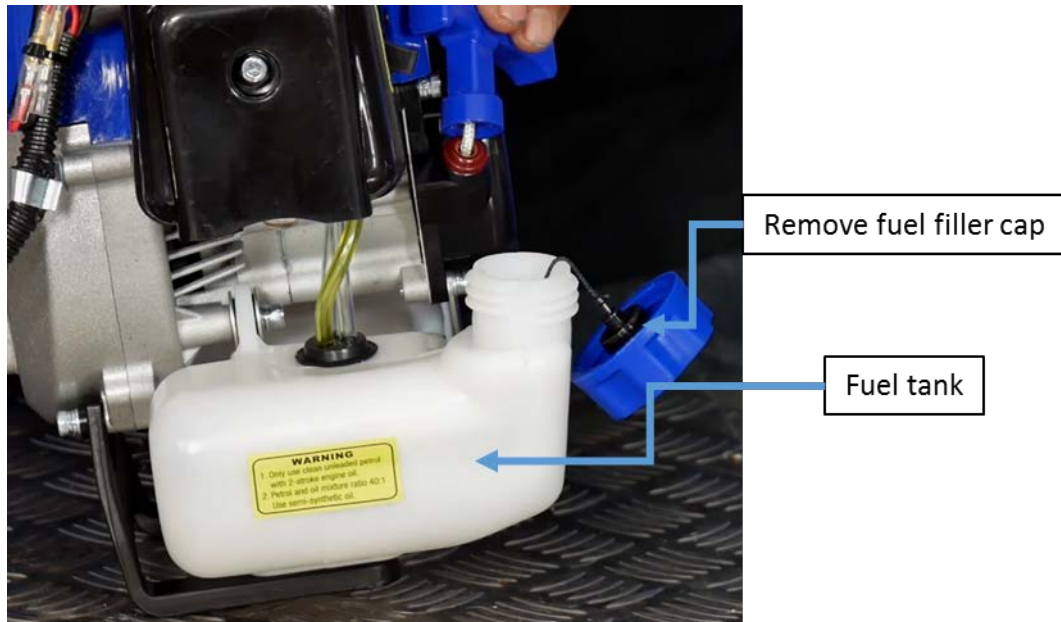



### 3. STARTING PROCEDURE

Fill with fuel/oil mixture, make sure the fuel cap is secure – see section 2.11. - Set the power switch on the handle to the ON position.



Pump the primer bulb about 8 to 10 times until fuel shows in the bulb.

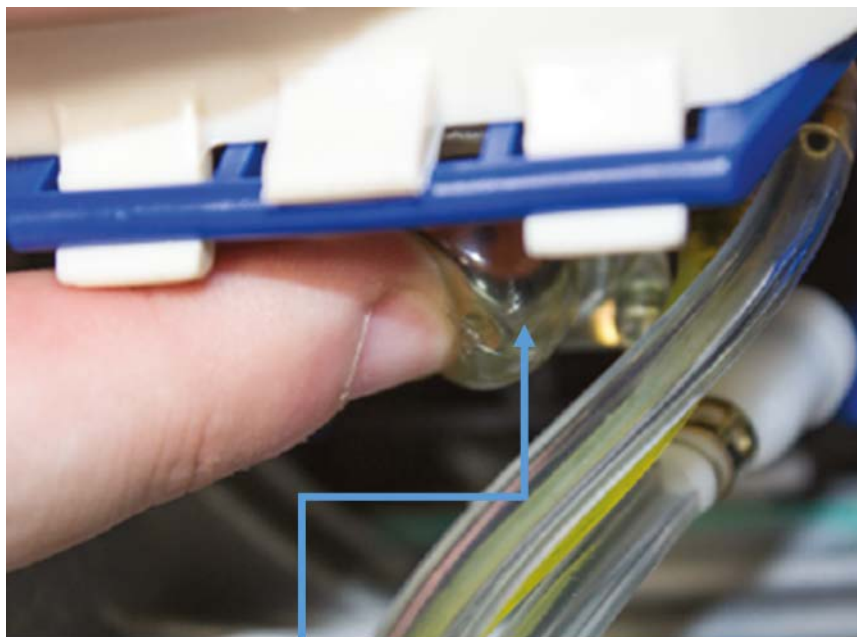

For COLD start move choke lever UP to start position.  
N.B. For a WARM/HOT start you will not need to do this.

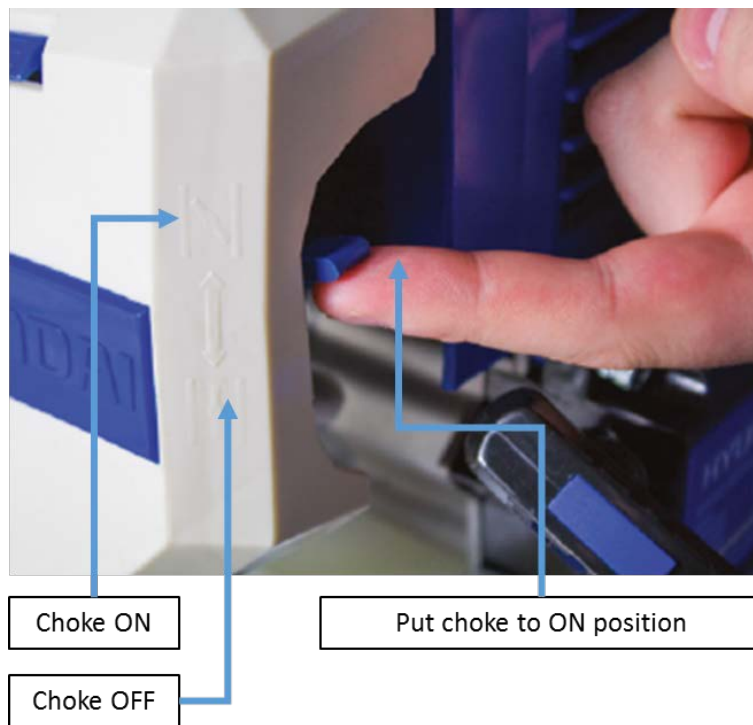

Place one hand on the machine, and using the other hand pull the recoil until you feel a resistance, then pull briskly. Repeat until machine starts.

When the engine starts and move the choke to the OFF position. DO NOT let go of the recoil handle instead allow the recoil cord to return gently. Once started you need to reduce the choke by slowly moving lever to RUN position if engine falters move choke between START/RUN positions and adjust until engine runs smoothly.



## 4. STOPPING PROCEDURE

- 4.1. Before stopping the machine allow the engine to cool down for a few minutes, by allowing it to run without throttle.
- 4.2. You **MUST** allow the cutting head to come to a full stop before carrying out any maintenance on the machine.

To STOP the machine release the throttle lever, allow the machine to cool down with no throttle then move the power switch to the OFF position.  
If not already in OFF position move the choke to the OFF position.



## 5. USING THE MACHINE

### 5.1. Trimming techniques.

#### CAUTION

If you are not familiar with this type of machine you should practice in a safe place.

5.1.1. ALWAYS clear the work area of cans, bottles, rocks, etc. Flying or whirling objects may cause serious injury and damage to users or bystanders. If an object is accidentally flung out from machine, immediately stop and check the machine

5.1.2. Always trim at high speeds.

5.1.3. Maneuverer the cutting head of the trimmer horizontally from one side to the other.

5.1.4. Keep cutting deck parallel with the ground.

5.1.5. DO NOT tilt the nylon cutting head during operation.

5.1.6. For correct cutting height carry out a test trim in advance in a test area.

5.1.7. NEVER let the machine run with damaged or defective parts.

5.1.8. Trimmer is to be used for trimming grass only.

5.1.9. NEVER raise the nylon cutting head above knee height during operation.

5.1.10. DO NOT use the machine on a slope or uneven ground or if there is the chance of slipping or losing the stability.

5.1.11. NEVER over cut – instead cut short lengths then cut successively lower heights.

#### CAUTION

ALWAYS stop the machine before removing grass deposits. To prevent overheating of the drive axle remove all tangled grass and weed fibre. The tangled grass and weed fibre/s prevent the shaft from cooling properly. Remove grass

deposits with a screwdriver or similar tool.

5.2. Trimming around trees.

5.2.1. Trim around trees carefully this will prevent damage to the tree, and tree bark.

5.2.3. Move around the tree in a clockwise direction. Approach grass/weeds with the tip of the cutting cord.

5.2.4. To replace worn out cord refer to section **2.7. Installing/Replacing cutting cord.**

## 6. MAINTENANCE

### WARNING

Always stop the engine and unplug the spark plug before doing any repairs or maintenance. Never touch the rotating nylon cord or blade.

Check and maintain fuel level regularly, and maintain the fuel/oil mix to the correct ratio. Frequently check the brush cutter and make sure that all grass deposits are removed from the trimmer head and trimmer guard.

At regular intervals, check the tightness of all nuts, bolts and screws.

If the blade hits an obstacle check for damage and if the machine vibrates badly stop the lawnmower and take it to a service dealer.

### CAUTION

Always refuel in a well-ventilated area with the engine off and spark plug HT cap removed.

Whilst carrying out maintenance you must wear appropriate Personal Protective Equipment (PPE). Suggested PPE Sturdy footwear, work gloves (especially when working near cord cutter blade), long trousers and hearing protection.

Component		Maintenance cycle				
		Each use	Every 3 mths or 15 hours	Every 6 mths or 50 hours	Every 12 mths or 100 hours	Every 24 mths or 300 hours
Air filter	Check	○				
	Clean		○ a			
Sparkplug	Check/Adjust				○	
	Change					○
Sparkplug electrode	Clean				○	
Cooling fins	Check/Clean			○		
Connections – nuts bolts screws etc.	Check and tighten as required	○				
Coupling	Examine			○ b		
Idle	Check/Adjust				○ b	
Valve clearance	Check/Adjust				○ b	
Spark arrester	Check/Clean	Every 300hours				
Fuel tank	Examine				○	
Fuel pipes	Examine					
Bevel gear	Fill	After 25 hours of use (For location of bevel gear grease nipple Section 9 Part Location.				

a = Increase maintenance intervals if operating in dusty environments. b = All maintenance operations - except those listed in the operating instructions, must be performed by qualified service personnel

## 6.1. Air filter.

### CAUTION

Never let the engine run without the air filter being fitted. A dirty air filter element affects the engine performance, increases fuel consumption and makes it difficult to start. If you notice a loss of engine power.

6.1.1. Remove the air filter cover by pressing down on clip and pulling cover forward.

6.1.2. Carefully lower the outer cover.

6.1.3. Once the outer cover has been lowered you can remove the nylon gauze filter element. If it is damaged replace it. Otherwise wash the element in clean soapy water, rinse in fresh water and allow to fully air dry before replacing filter element.

N.B. To reinstate the filter assembly reverse the above process.

Push clip down to  
release air filter cover



Gauze filter element

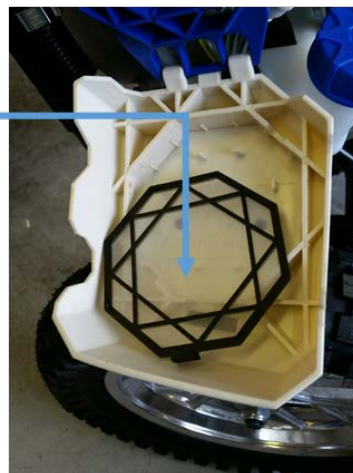
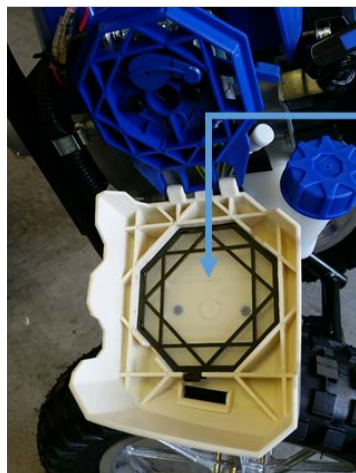

## 6.2. Spark plug.

### WARNING

The spark plug MUST be fully tightened otherwise the engine will overheat causing damage. Always complete the following steps after the engine has been turned off and allowed to cool down.

6.2.1. To make sure the engine runs correctly a spark plug gap of 0.6 -0.7 mm must be maintained and the spark plug must be free of carbon deposits.

6.2.1. To remove the spark undo the cover then pull back the protective cover. Pull off the HT lead and then undo the spark plug using the supplied box spanner in an anti-clockwise direction.

6.2.3. Once the plug has been removed check it for visual damage, electrode wear and carbon deposits. Replace a damaged or badly worn spark plug. Clean off any carbon deposits by using a soft brass brush.

6.2.4. Check the gap with a feeler gauge and adjust electrode at the correct gap of 0.6 -0.7 mm.

6.2.5. Check the washer (replace as required) of the spark plug. Refit the spark plug by hand to make sure it does not cross thread, tighten the spark plug to a torque of 12/15Nm.

6.2.6. To refit spark plug reverse the above process.

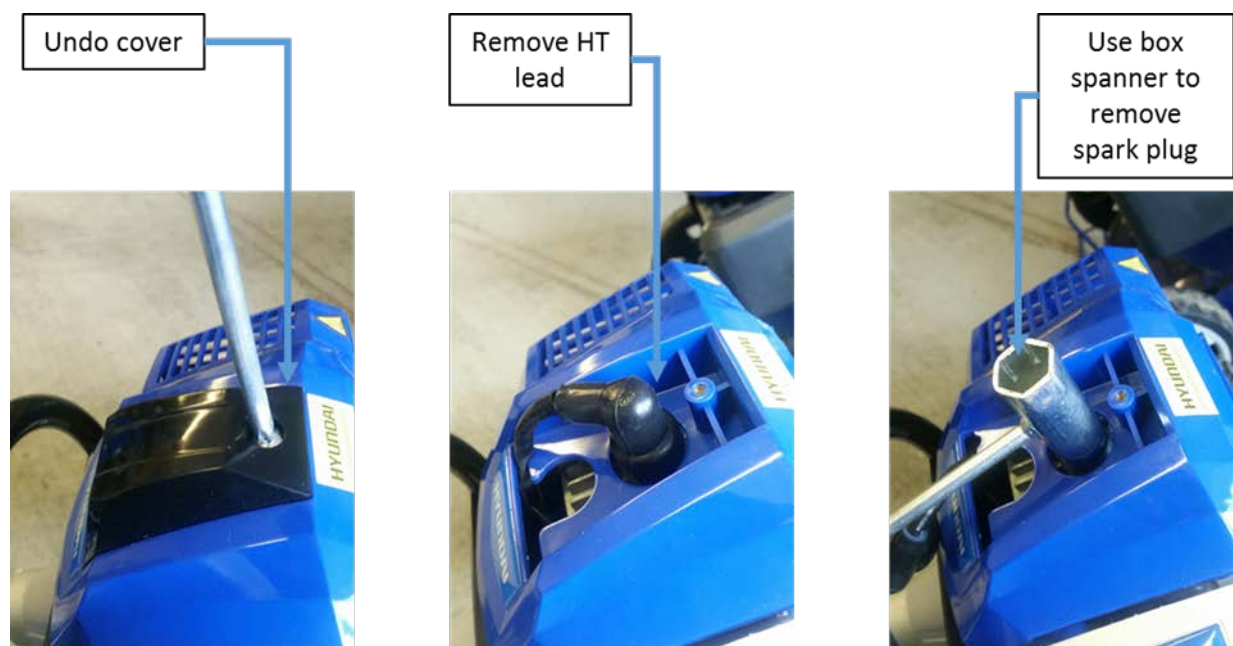

### 6.3. Cutter blade sharpening.

#### **WARNING**

When sharpening cutter blade wear suitable safety gloves.

- 6.3.1. Remove the cutting blade from the guard.
- 6.3.2. Put cutting blade securely into a vice.
- 6.3.3. Sharpen the blade with a suitable flat file.
- 6.3.4. Make sure that you maintain the original cutting angle.

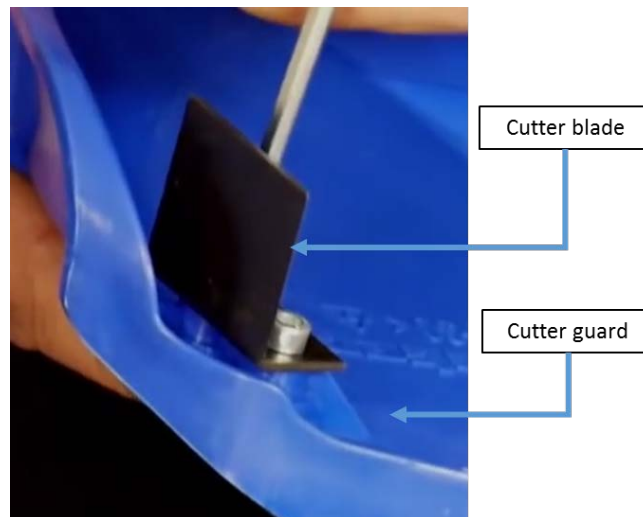

### 6.4. Storage.

#### **WARNING**

If you do not follow these steps, deposit may arise in the carburetor. This will cause starting difficulties and may cause permanent damage.

- 6.4.1. Perform all the general maintenance that the maintenance section of your 'User Manual' is recommended.
- 6.4.2. Clean the outside of the machine, drive axle, shield and nylon cutting head.
- 6.4.3. Remove all fuel from the fuel tank, by undoing fuel cap and tipping content into a suitable container. DO NOT use stale fuel/oil mixture in the next season.
- 6.4.4. After all the fuel has been removed from the fuel tank. Start the engine. Allow the engine to run in idle until engine stops alone. This allows the fuel to be removed from the carburetor.
- 6.4.5. Allow the engine to cool down for about five minutes.
- 6.4.6. Remove the spark plug and pour 1 teaspoon of clean 2-cycle oil into the combustion chamber. Slowly pull the starter rope several times to coat internal components. Replace the spark plug.
- 6.4.7. Store the machine in a cool, dry place away from any source of ignition such as an oil burner, water heater etc.

### 6.5. Transporting the machine.

- 6.5.1. When transporting the machine make sure that no fuel is allowed to leak out.
- 6.5.2. DO NOT allow the trimmer to come into contact with persons, animals and property.



## 7. TROUBLESHOOTING

### CAUTION

7.1. If troubleshooting does not solve the problem, contact your dealer or the manufacturer directly. Use only original parts approved by the manufacturer, otherwise a hazard risk arises.

#### NO SPARK

Possible causes;

1. Carbon deposit between electrodes of the spark plug.
2. Ignition coil defective flywheel magneto too weak.

Possible corrective actions;

1. Clean the spark plug. Adjust the gap to 0.6 ~ 0.7mm, Replace the spark plug.
2. Replace the Ignition coil or the flywheel.

#### WEAK SPARK

Possible causes;

1. Too much fuel in the combustion chamber, poor fuel or water in tank.
2. Blocked fuel line

Possible corrective actions;

1. Remove spark plug and dry, replace fuel.
2. Clean the carburetor and clean the lines.

#### NORMAL FUEL SUPPLY BUT WEAK COMPRESSION

Possible causes;

1. Worn piston rings, spark plug not tightened, the cylinder head is not tightly wrong valve clearance or ignition.

Possible corrective actions;

1. Replace or adjust.

#### NORMAL FUEL SUPPLY AND POOR SPARK

Possible causes;

1. Poor contact between spark plug cap and spark plug.

Possible corrective actions;

1. Check or exchange.

#### MOTOR DOES NOT COME UPTO SPEED

Possible causes;

1. Choke is in "cold start" position, exhaust system does not clog air supply, worn Movable elements, spark weak, valve clearance to big, sooty cylinder head.

Possible corrective actions;

1. Open choke, exhaust system ignition coil exchange check or replace flywheel Adjust spark plug.

#### POWER RUNS OUT

Possible causes;

1. Congested fuel lines to the carburetor. Spark plug gap incorrect.

Possible corrective actions;

1. Unblock/Replace lines and carburetor. Reset spark plug gap.

#### NOISY ENGINE

Possible causes;

1. Incorrect choke lever position, or damage to crankshaft.

Possible corrective actions;

1. Check and correct choke lever position. Check and/or replace crankshaft.

#### LEAKING CARBURETTOR

Possible causes;

1. Failure of the non-return valve on the fuel tank lid. Worn carburetor gasket.

Possible corrective actions;

1. Replace the fuel cap. Replace the carburetor seal.

## 8. SPECIFICATION

	MODEL	HYWT5080
ENGINE	Engine type	Single cylinder, 2 stroke air cooled
	Engine size – cc	50.8
	Fuel tank capacity – ml	1200
	Noise level – dB (A)	119
	Power – kw	1.56
	Start method	Recoil
	Fuel type/ratio	Fresh unleaded petrol – Semi-synthetic 2 stroke/40:1
MACHINE	Bevel gear grease type/qty ml	High temperature gear grease/25
	Head line length/diameter mm	2 x 270/2.5
	Cutting diameter mm	450
	Gross weight – kg	15.96
	Dry weight – kg	14.06
	Fully assembled dimensions L x W x H - mm	1390 x 425 x 1185

# 9. PART LOCATIONS

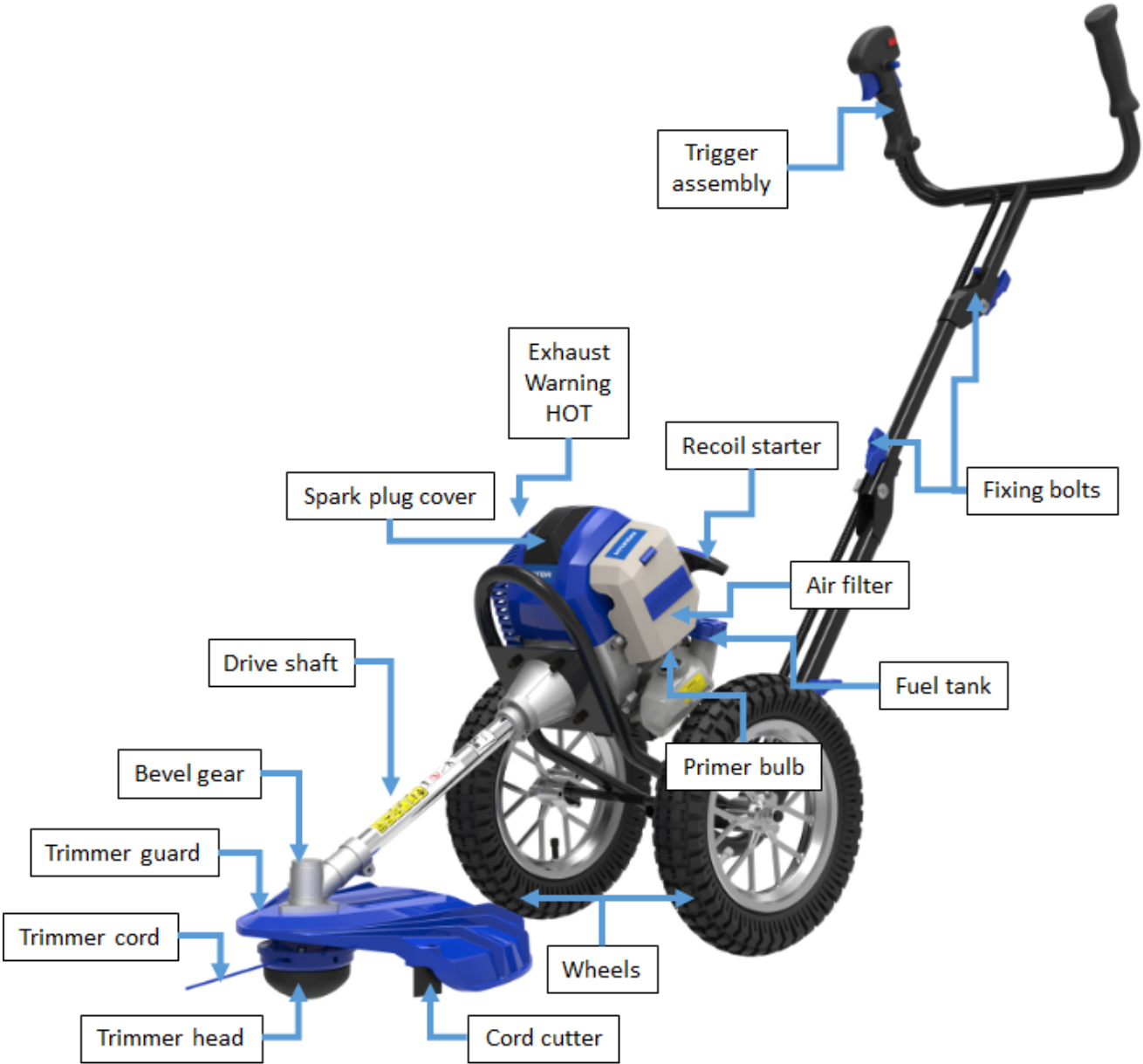

## 10. DECLARATIONS OF CONFORMITY

Genpower Ltd confirms that these Hyundai products conform to the following CE Directives;  
2006/42/EC Machinery Directive  
2004/108/EC EMC Directive  
2000/14/EC, Amended by 2005/88/EC Noise Emissions Directive  
97/68/EC\_2010/26/EC NRMM Emissions Directive

### EC DECLARATION OF CONFORMITY

The undersigned, as authorised by: **Genpower Ltd**

Declares that the following equipment manufactured under licence by Hyundai Korea

Conforms to the Directive: -

**2000/14/EC, Amended by 2005/88/EC (as amended)**

of the European Parliament and of the council on the approximation of the laws of the Member States relating to the noise emission in the environment by equipment for use outdoors.

Equipment Category: **Garden Machinery**  
Product Name/Model: **HYWT5080**  
Type/Serial No: **Wheeled Trimmer**  
Power: **1.56 kW**  
Cutting Diameter/Length mm: **Trimmer 400 - 450**

The technical documentation is kept by: **Kevin Stanley, Genpower Ltd,  
Isaac Way, Pembroke Dock,  
Pembrokeshire, SA72 4RW.**

The conformity assessment procedure followed was in accordance with annex V of the Directive.

Notified Body: **TÜV Product Service Co Ltd,  
TÜV SÜD Certification & Testing (China),  
Shanghai Branch,  
3-13F 151 Heng Tong Road,  
Shanghai 2000070. PR China.**

Certificate Number/Technical report number: **70.403.15.498.13**

Measured Sound Power Level: **119dB(A)**

Guaranteed Sound Power Level: **119dB(A)**

A copy of this certificate has been submitted to the European Commission and to EU Member State United Kingdom.

Place of Declaration: **Pembroke Dock, SA72 4RW**

Date: **10<sup>th</sup> January 2016**  
Signed by: **Kevin Stanley**  
Position in Company: **Product Manager**  
Name and address of manufacturer or Authorised representative:

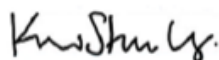

**Genpower Ltd,  
Isaac Way, Pembroke Dock,  
Pembrokeshire, SA72 4RW.**

## 11. RECYCLING & PRODUCT DISPOSAL

11.1. We do not offer a takeback scheme for the recovery of Waste Electrical Electronic Equipment (WEEE) & Batteries instead the responsibility to dispose of WEEE and or Batteries is passed onto you by us. So when it becomes necessary to dispose of your machine you must take it to your local Civic Amenity Site. For further information please contact your Local Authority for disposal advice.

11.2. You MUST make sure that all unused oil and fuel is disposed of correctly either beforehand or at your local Civic Amenity Site. Under NO circumstance must any oil and fuel be put down any drains.

11.3. Waste Electrical Electronic Equipment (WEEE) recycling.



11.3.1. Certain products contain WEEE waste which should not be disposed of in your domestic waste.

11.3.2. You MUST recycle WEEE in accordance with your local authority or recycling centre.

11.4. Battery recycling, certain products contain batteries which should not be disposed of in your domestic waste.



11.4.1. You MUST recycle batteries in accordance with your local authority or recycling centre.

11.5. Unwanted packaging materials should be sorted and taken to a recycling centre so it can be disposed of in a manner which is compatible with the environment.

11.6. The following symbol means that you should 'Reduce – Reuse – Recycle'.



11.7. We are a Member of the VALPAK National Compliance scheme and our registration number is **RM08660**.

11.8. For further information about disposal please contact your Local Authority.

11.9. You can also get more advice and guidance about recycling at the following website <http://www.recycle-more.co.uk>

11.10. Should you pass this product onto another user either sold or loaned you MUST pass on this user manual. This will make sure that all other users can use and maintain the machine safely.

## 12. CONTACT DETAILS

### POSTAL ADDRESS

Genpower Ltd, Isaac Way, London Road,  
Pembroke Dock, Pembrokeshire,  
SA72 4RW. UK.

### TELEPHONE

+44 (0) 1646 687880

### FAX

+44 (0) 1646 686198

### TECHNICAL E-MAIL

[service@genpower.co.uk](mailto:service@genpower.co.uk)

### WEBSITE

[www.hyundaipowerequipment.co.uk](http://www.hyundaipowerequipment.co.uk)

## 13. MANUAL UPDATES

13.1. Our manuals are constantly being reviewed and updated. Should you find an error, omission or something you find unclear please contact your dealer for assistance. E&OE.

13.2. Our latest manuals are also placed online.

13.3. We reserve the right to make any modifications without prior notice whenever necessary.

## 14. WARRANTY

14.1. For specific warranty and warranty exclusions details for your product please visit our Customer services section on our website at [www.hyundaipowerequipment.co.uk](http://www.hyundaipowerequipment.co.uk)  
If you require a hard copy of Warranty details please contact aftersales on [aftersales@genpower.co.uk](mailto:aftersales@genpower.co.uk)



# HYUNDAI

## **GENPOWER LTD**

Isaac Way, London Road  
Pembroke Dock, UNITED KINGDOM, SA72 4RW  
T: +44 (0) 1646 687 880 F: +44 (0) 1646 686 198

E: [info@hyundaipowerequipment.co.uk](mailto:info@hyundaipowerequipment.co.uk)

---

[www.hyundaipowerequipment.co.uk](http://www.hyundaipowerequipment.co.uk)